

M•LOCKS

Straightbolt EM3520 EM3550

Mounting
instructions
V04 EN



M•LOCKS BV

Vlijtstraat 40 • 7005 BN Doetinchem • The Netherlands • www.m-locks.com



1 IMPORTANT INSTRUCTIONS

- Before mounting the lock, please read the instructions for use carefully.
- Ensure that you **only** program the lock when the **safe is open**.
After changing the code, always try the code several times with the safedoor open.
- **Only after several positive function test (opening / closing) the safedoor can be closed.**
- Each key entry is confirmed by an audible tone and visual signal. These signals are not referred to in the description that follows.
- You have a maximum of 10 seconds for each key entry. If you do not make an entry via the keypad during this period of 10 seconds, the entry procedure will automatically abort. You must then start again from the beginning.
- After entering a valid code, you will hear two audible tones. An invalid entry will trigger a long tone.
- If you accidentally enter an invalid code at the first attempt, you must wait 20 seconds before you re-enter the code.
- Our products fulfil the EN1300 requirements regarding resistance against electrostatic charge. In fact it may happen that the electrostatic charge of a user exceeds the extreme value many times. That's why we are asking you to touch the metal surface of the safe for discharging before operating the lock.

- !** The certifications of our locks are valid only if used together with the entry units indicated on the respective certificates. As soon as an entry unit not specified on our certificates is used, the certification of the lock expires immediately.

! **Caution!**

- The lock has been designed for use in a temperature range from +10°C to +50°C and a non-condensing humidity range from 30% to 80%.
- It may only be cleaned with a moist cloth (do not use aggressive cleaning agents).
- The lock may only be installed by qualified fitters.
- The lock may not be lubricated.
- Never open the lock housing. If it is necessary to disassemble the hardware, only do so in accordance with the technical instructions. If you fail to do so, the lock may no longer function properly and you will forfeit your right to warranty.

2 CHARACTERISTICS

The Straightbolt lock can be mounted in all four mounting directions. The mounting dimensions are standard. The lock is delivered with metric (M6) mounting screws.

When a valid code has been entered, the lock electronics remove the blocking for 3 seconds and the bolt can be moved into the housing by turning an internal driving cam with a turning entry unit or a knob. After moving the bolt into LOCKED position, the Straightbolt automatically secures.

3 GENERAL

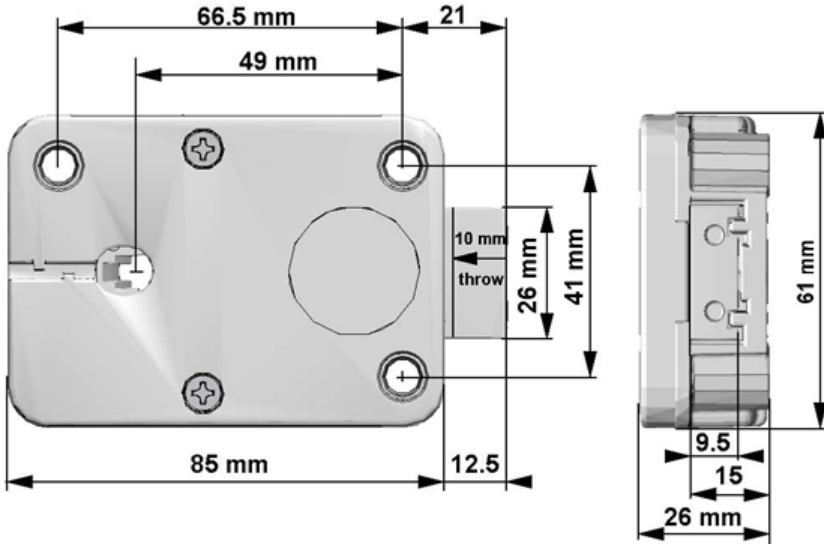

The VdS recognition of this lock is based on this mounting instruction. Read carefully.

The force applied to the lock bolt should not exceed 1 kN. If higher force is applied, please consult with the testing institute (i.e. UL, VdS). Only use supplied screws to mount the lock. Fix the lock hand-tied. The maximum allowed cable/spindle-hole diameter is 11 mm.

The lock has to be fitted exclusively on steel secure storage. The mounting base also must be made of steel. Installation on other materials only after consultation M-LOCKS or VdS.

It is recommended to prevent access to unauthorized persons to safety-relevant parts of the high-security lock when the safe is open. For example by a with a screws fixed interior cover.

The lock housing must be protected against destructive attacks from outside with suitable protective materials.

4 REQUIREMENTS AND MOUNTING INSTRUCTIONS

The force applied to the boltwork on the lock bolt has to be limited to 1 kN (p. E. by a preconceived breaking point). Please contact your manufacturer if higher forces are needed. Only use supplied screws to mount the lock.

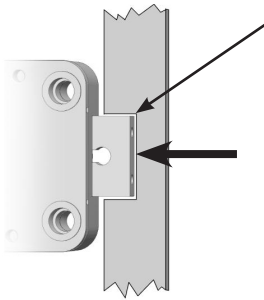

In the LOCKED position, there should be approximately 1 mm clearance between the lock bolt and the cavity in the blocking bar of the boltwork. The lockbolt must move freely into the cavity.

Every bolt mounting should not exceed 0.5 Kg/ 1 lb. [corresponds to a force of 5N].

Fix the screws handtight! Only use supplied screws!

Mount the entry unit following the manufacturer's instruction.

The spindle should stick into the lock between 10 to 15 mm.

Make sure the cable is in the groove all along the spindle length.

Guide the cable connector from keypad through lock via square hole in cam.

Double check that keypad is in the 0 position. Whilst holding the cable taut, fit the lock on the spindle and secure with the three mounting screws. Insert the connector of the entry unit in the outer (ENT) position. If battery/alarm box is used connect to inner (BAT) position. Check that the connector(s) is completely seated. (To remove the connector(s), lift it up and carefully pull it out.)

To tie the cable, push it into the cable channel in the lock cover.

In the entry unit or battery/alarmbox, connect a 9V ALKALINE Duracell, Industrial or Energizer battery.

5 FUNCTIONAL TEST

Check the keypad

If the lock does not react, follow the procedure below to check that your keypad is working.

Press and hold key '5' until you hear a double tone. The LED will illuminate when performing the following actions:



Next, press all of the keys one by one and one after the other.



If the key = OK 

If the key = not OK , the test will be aborted.

If one or more keys do not operate properly, please contact your supplier.

Mechanical Test

- Enter code [1,2,3,4,5,6]. The lock emits a double signal for the correct code.
- Turn keypad/knob clockwise until stop. Lock bolt must move freely.
- Boltwork / door can be opened.

Repeat the mechanical test (opening / locking) several times before closing the safe door!

6 DATASHEET

	EM3520 / EM3520 S	EM3550 / EM3550 S
Opening	Manually	Manually
Locking	Manually	Manually
Blocking element	Motor	Motor
Mounting dimensions	Standard	Standard
Possible mounting positions	4	4

	EM3520 / EM3520 S	EM3550 / EM3550 S
Power supply	9V Alkaline Duracell, Industrial- or Energizer battery	
Software	Codes	2 (6 digits)
	Manager Codes	1
	User Codes	1
	Time delay / open window	01-99 Min / 01-19 Min
	Battery low signal	Ja
	Dallas Key and code	-
	Silent alarm	-
	Dual mode	-
	Audit 2000 Events with Date & Time	-
	Manipulation protection	5 minute lockout after 4 consecutive wrong codes

7 NOTES

M•LOCKS



M•LOCKS BV

Vlijtstraat 40 • 7005 BN Doetinchem • The Netherlands • www.m-locks.com