

# Mechanical Combination Lock

## Technical Manual Mounting Instructions

### ML6740



The VdS recognition of this lock is based on this mounting instruction. Read carefully.

The force applied to the lock bolt should not exceed 1 KN. If higher force is applied, please consult with the testing institute (i.e. UL, VdS). Only use supplied screws to mount the lock. Fix the lock handtied.

The lock has to be fitted exclusively on steel secure storage. The mounting base also must be made of steel . Installation on other materials only after consultation M - LOCKS or VdS .

It is recommended to prevent access to unauthorized persons to safety-relevant parts of the high-security lock when the safe is open . Par example by a with a screws fixed interior cover.

The lock housing must be protected against destructive attacks from outside with suitable protective materials .

### CHARACTERISTICS

The ML 6740 is a manipulation proof 3-wheel combination lock with new features making it very easy to mount. VdS KI.2, EN1300 Class B, ECB-S, CNPP, IMP, DNV.

The lock has the standard foot print (66,7x41mm) and can be mounted in all four mounting-directions. (HR, HL, VU, VD)

Measurements: 85mm x 61mm, x 29mm. Lock bolt: 25mm x 8mm with two M4 holes in the bolt head. Bolt Travel: 8mm.

The lock needs no spline key. It works with a square 6x6mm shaft as the spindle.

Two optional locking bars can be inserted to make a 3-way locking system.

### Mechanical Dials

This mechanical lock compatible with the following M-LOCKS dials:

CS-serie	MD-serie	ST-serie	KL1060	KL1560

For more information, please read the technical description and mounting instruction of the dial and ring assembly.

Due to the square shaft the lock is **not** compatible with dials that have a round, threaded spindle.

# Mechanical Combination Lock

## DIMENSIONS / MOUNTING INSTRUCTIONS

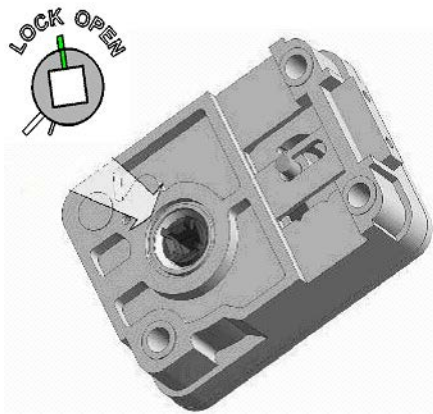
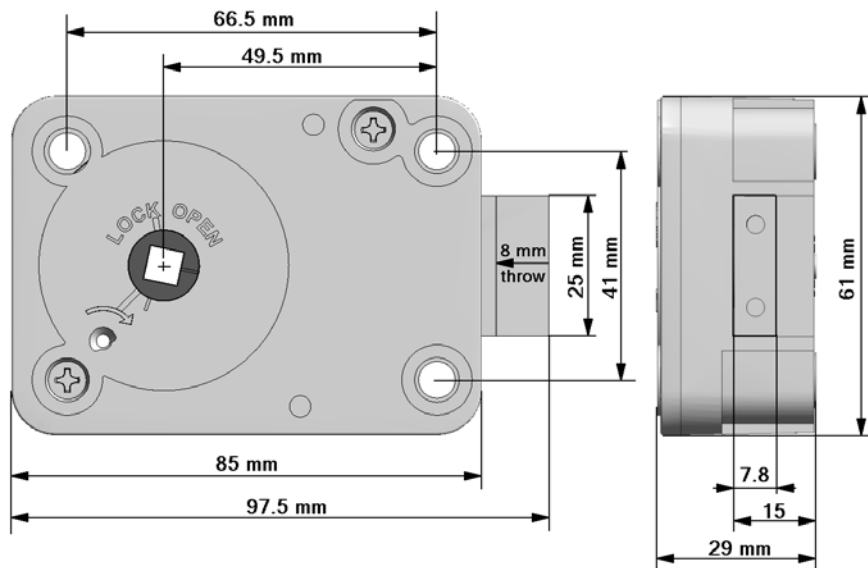

The Lock is delivered with the Bolt retracted and ready for mounting. Do not move the cam (part with square hole) or the bolt. During installation the **bolt must stay in retracted position and the cam lined up as shown left.**

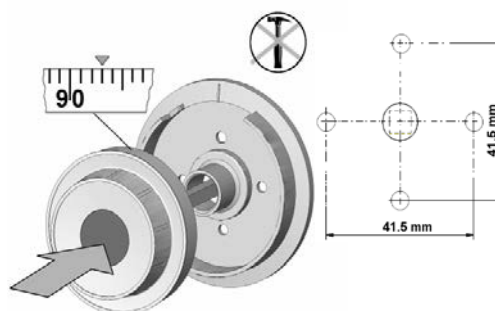
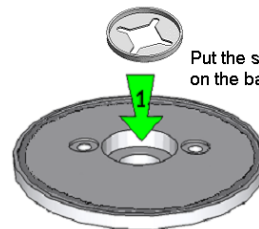
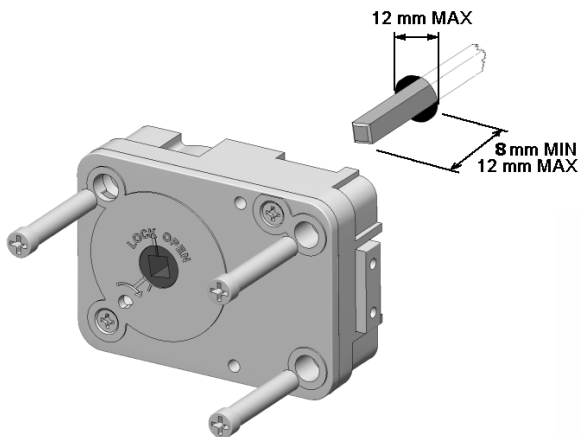

Only use the delivered 3 mounting screws (3x M6 with US 1/4" available on demand) and fasten handtight. (Torque approximately 3,5 Nm). With the lock in OPEN-position (bolt retracted) hold the dial in a way that approximately "93" is under the opening index and push it with some pressure into the lock. The shaft cannot be pulled out.

# Mechanical Combination Lock



Turn Dial LEFT to extend the bolt. The bolt must slide easily to the end position and should not be restricted by the bolt work

Delivered Factory Code is: 4xL to 50.

4x  Turn LEFT and pass "50" three times and stop exactly on "50" under the opening index the fourth time.

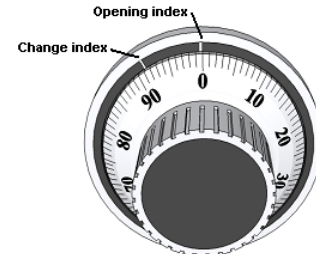

**Due to installation tolerances it is possible that the code may have shifted up to two numbers up or down. This shifting is normal and will be eliminated once the code is re-set. If the lock does not open on "50", try to open at „48“ then "49", "51" or "52".**

Also due to these tolerances it is important to re-set the code after installation.

With door open, move the bolt work and lock to locked position.  
Dial the code at which the lock opened on the CHANGING INDEX.

Example: If the lock opens at "49."  
4 x LEFT until "49" stops exactly at the Changing Index

1. **Carefully insert change key on the inside of the safe door.**  
Slightly wiggle if necessary.
2. **Turn change key as shown clockwise to the stop (approx. 90 deg.)**

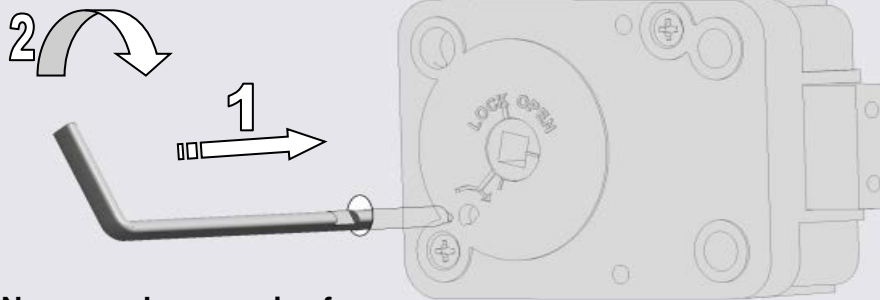

### Never apply excessive force

If change key cannot be inserted or turned, the correct code has not been dialed to the Changing Index on the dial. Take out the key and dial the valid code again.

### Change Keys

If installers use the same change key to set up several locks, it is important to inspect the change key regular basis.



If the change key is bend or shows signs of wear it needs to be replaced. Otherwise the new code will not be set exactly as dialed.

Now dial your factory code using the CHANGING INDEX.

**\* We suggest you set the code to 10-20-30 as that matches the end-user instruction M-LOCKS provides.**

**The last number must be higher than 20. Each number has to be at least 4 increments apart from the others. For example: 49-45-41 and not 51-52-53.**

# Mechanical Combination Lock

- 4 x  Turn LEFT, pass first code number three times and stop exactly on the number on the **Changing Index** the fourth time.
- 3 x  Turn RIGHT, pass second code number twice and stop exactly on the number on the **Changing Index** the third time.
- 2 x  Turn LEFT, pass third code number once and stop exactly on the number on the **Changing Index** the second time and stop.

After the new Code is completely entered, **turn change key LEFT and remove it**. The new Code is installed.

When turning the dial, if a number is passed, start over at the beginning.

- **Try the new code several times (using Opening Index) before closing the door!**
- **Please note! If the code is lost, the warranty will void and the lock will be permanently unusable.**

## DATA SHEET

<b>Mechanics</b>	
Opening	manually
Locking	manually
Blocking element	3 Wheels
Mounting dimensions	standard
<b>Certifications</b>	
VdS	Class 2
EN1300, ECB-S, CNPP, A2P	Class B
UL	Group 2M
DNV	158-2 Listed
IMP	Klasa B

### What if ...

#### ...accidentally the cam got moved before installation?

As long as the code has not been changed with the change key, the lock can be prepared for mounting following the steps below:

1. Hold the lock so that you look at the cover and the bolt is to the right.
2. Turn the cam clockwise minimum 4 complete turns and stop when the cam is lined up as shown in figure 1.
3. Turn cam counterclockwise until lock opens. The cam should be lined up with the "LOCK OPEN" line on the cover (see figure 2).

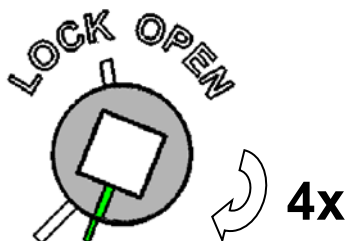

figure 1

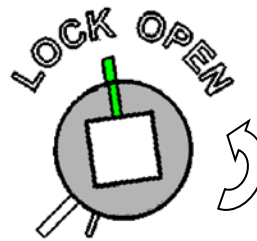

figure 2

#### ...the dial is hard to turn or the dial is rubbing on the dial plate?

Loosen the screw that holds the shaft in the dial and pull out the dial slightly. Then tighten the screw hand tight. Do not over tighten as that will pull the dial back in. Use liquid thread-lock like Loctite™ if required.

# Mechanical Combination Lock

## Technical manual Mounting instructions

### ML6785

**The VdS recognition of this lock is based on this mounting instruction. Read carefully.**

The force applied to the lock bolt should not exceed 1 KN. If higher force is applied, please consult with the testing institute (i.e. UL, VdS). Only use supplied screws to mount the lock. Fix the lock handtied.

The lock has to be fitted exclusively on steel secure storage. The mounting base also must be made of steel. Installation on other materials only after consultation M - LOCKS or VdS.

It is recommended to prevent access to unauthorized persons to safety-relevant parts of the high-security lock when the safe is open. Par example by a with a screws fixed interior cover.

The lock housing must be protected against destructive attacks from outside with suitable protective materials.

### CHARACTERISTICS

The **ML6785** is a manipulation proof 3-wheel combination lock, VdS Kl. 2, EN1300 Cl. B certified, and very easy to mount.

The lock has the standard foot print (66,5 x 41mm) and can be mounted in all four mounting-directions. (RH, LH, VU, VD)

Measurements: 85mm x 61mm, x 29mm. Lock bolt: 25mm x 8mm with two M4 holes in the bolt. Bolt travel: 8mm.

Two optional locking bars (ML6790) can be inserted to make a 3-way locking system.

### DIMENSIONS / MOUNTING INSTRUCTIONS

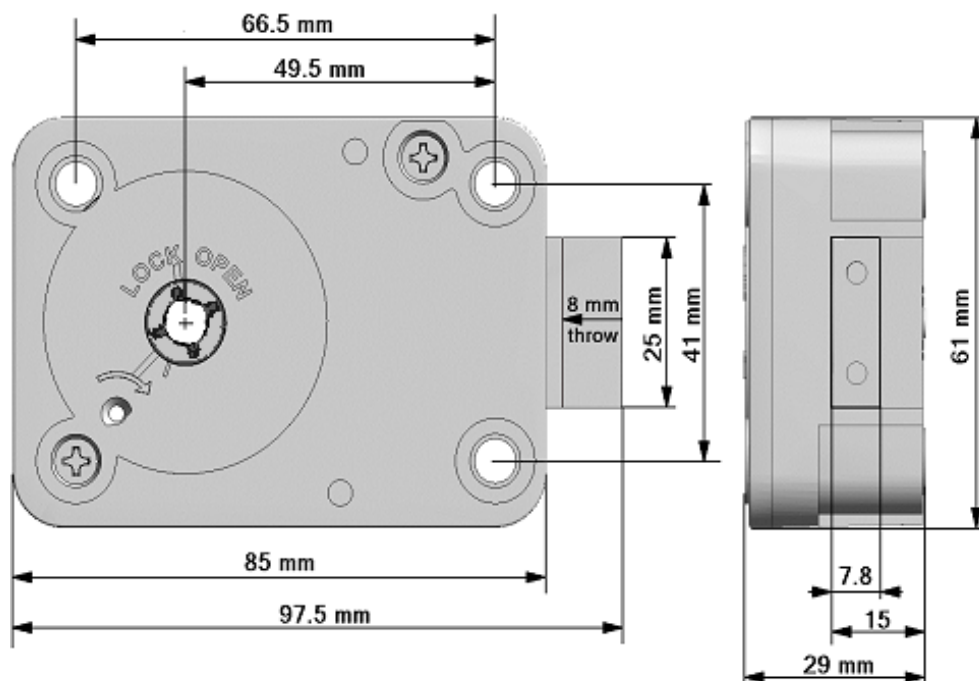

# Mechanical Combination Lock

## 1. Lock assembly

The lock can be installed in all 4-installation directions. The combination lock has a standard footprint of 66.5 x 41mm and is mounted on the bolt work with the 3 provided fixing screws. Fix hand tied.

The bolt work must block the bolt sufficiently on both sides in slide-out position. (8mm) But if one side is blocked a support must be fixed on the opposite side. The margin between closing point and respectively support and bolt is 0.5-1mm. The support is not necessarily if the side pressure is limited to 1.8kN. The bolt counter-pressure maximum 1kN.

## 2. Assembly of the dial:

Spindle has US-screw-thread 5/16-40 UNS-2A (spindle groove on "44"). Assemble the ring so that the opening symbol is perpendicular above. Cut spindle to length so that the spindle-end levels with the cam. Don't let spindle stick out. Twist dial hand tight in the cam and reverse approximately rotation until the correct spline key position. Spelling ca.0,5mm axial.

The spindle transit through the armouring can have a maximum diameter of 10-12mm.

## 3. Spline key position

Depending upon installation of the lock there are 4 spline key positions possible, which are indicated on the cam:

**RH, LH, VU, VD.**

Seen from the assembly side:

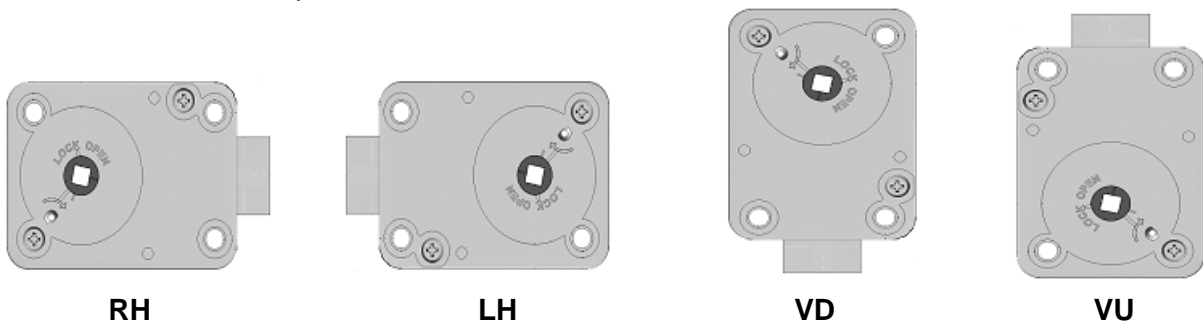

The correct spline key position is very important, because otherwise the "prohibited area" (last figure not between 0-20) moves in the operational range and can lead to lock malfunctions.

## 4. Place the spline key

If the spindle groove is on the correct spline key position drive the attached spline key carefully in, so that the nose lies gently on the spindle.

## 5.



Turn dial LEFT to extend the bolt. The bolt must slide easily to the end position and should not be restricted by the bolt work.

# Mechanical Combination Lock

Delivered Factory Code is: 4xL to 50.

4x  Turn LEFT and pass "50" three times and stop exactly on "50" under the opening index the fourth time.

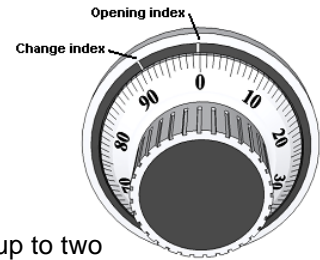

Due to installation tolerances it is possible that the code may have shifted up to two numbers up or down.

Also due to these tolerances it is important to re-set the code after installation.

With door open, turn the bolt work and lock to locked position.

Dial the code at which the lock opened, on the CHANGING INDEX.

Example: If the lock opens at "49.

4 x LEFT until "49" stops exactly at the Changing Index

1. **Carefully insert change key on the inside of the safe door.**  
(Slightly wiggle if necessary.)
2. **Turn change key as shown clockwise to the stop** (approx. 90 deg.)

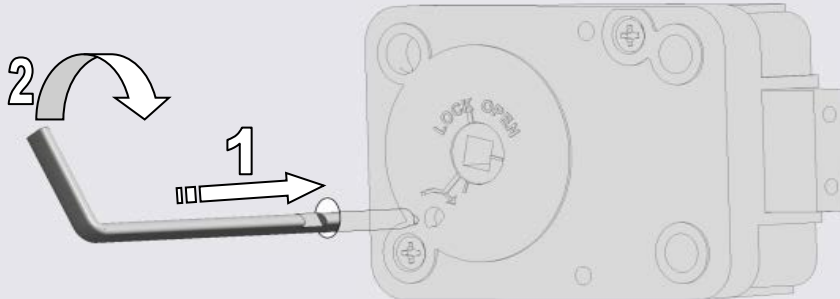

### Never apply excessive force

If change key cannot be inserted or turned, the correct code has not been dialed to the Changing Index on the dial. Take out the key and dial the valid code again



### Change Keys

If installers use the same change key to set up several locks, it is important to inspect the change key regular basis.

If the change key is bend or shows signs of wear it needs to be replaced. Otherwise the new code will not be set exactly as dialed.

Now dial your new code using the CHANGING INDEX, f.e. 10-20-30.

**(see user instructions of the lock)** (The last number may not be between 0 and 20)

- 4 x  Turn LEFT, pass first code number "10" three times and stop exactly on the number on the **Changing Index** the fourth time.
- 3 x  Turn RIGHT, pass second code number "20" twice and stop exactly on the number on the **Changing Index** the third time.
- 2 x  Turn LEFT, pass third code number "30" once and stop exactly on the number on the **Changing Index** the second time.

When turning the dial, if a number is passed, start over at the beginning.

After the new code is completely entered, **turn change key LEFT and remove it.** The new code is installed.

**Try the new code several times (using Opening Index) before closing the door!**

## DATA

# Mechanical Combination Lock

<b>Mechanical</b>	
Opening	manually
Locking	manually
Blocking element	3 wheels
Manipulation-proof	Yes
Mounting dimensions	Standard
<b>Certification</b>	
VdS	Klasse 2
EN 1300	Class B
ECB-S, CNPP, A2P	Class B

## What if ...

### **...accidentally the cam got moved before installation?**

As long as the code has not been changed with the change key, the lock can be prepared for mounting following the steps below:

1. Hold the lock so that you look at the cover and the bolt is to the right.
  2. Turn the cam clockwise minimum 4 complete turns and stop when the cam is lined up as shown in figure 1.
- Turn cam counterclockwise until lock opens. The cam should be lined up with the "LOCK OPEN" line on the cover (see figure 2).

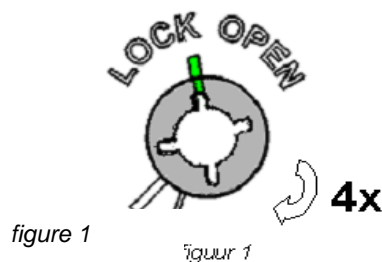

**Try the new code several times (using Opening Index) before closing the door!**

**Please note! If the code is lost, the warranty will void and the lock will be permanently unusable.**